

**50.80.02**  
**Straight Vertical**  
**Pattern**  
**Storm (Scupper) Valves**

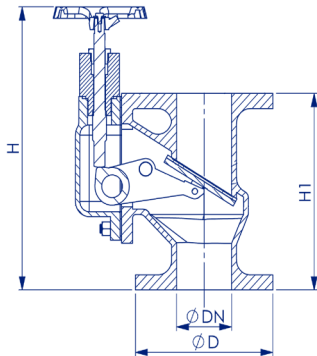

**Part No. 50.80.02**  
**Ductile Iron Body With Closing Device**

SIZE	DN50	DN65	DN80	DN100	DN125	DN150
H1	200	240	260	300	350	400
H	356	396	450	490	572	622
D	165	185	200	220	250	285

Storm valves also known as scupper valves, are basically swing check valves which can be supplied with or without a closing device. They are used in sanitary discharge pipelines which have a ship-side exit, and prevent sea water entering the system during heavy sea.

**Features & Benefits**

- Classification society survey can be arranged
- 3.1 & 3.2 certificates available on request
- Optional open/shut indicators
- Flanged PN16 (others on request)

**Pressure & Temperature**

Ductile Iron & Cast Steel:-  
4 Bar @ 80°C  
Bronze:-  
1 Bar @ 80°C

STANDARD MATERIALS		OPTIONAL MATERIALS (Others available on request)
Body/Bonnet	Ductile Iron (GGG40)	Cast Steel (GS-C25), Bronze (LG2)
Disc	Bronze (LG2)	
Stem	Bronze (LG2)	
Flap	NBR Faced	

Do you require class approved valves? Contact sales for availability.

